

NICKEL AUTOCLAVE

EXECUTIVE SUMMARY

The autoclave circuit includes one autoclave, complete with agitators, agitator seals, and heating coils.

The autoclave was originally intended for the reduction of nickel from a metals bearing ammonium sulphate solution under hydrogen atmosphere at elevated temperature and pressure.

The design conditions of the autoclave are 600 psig at 500°F (41.4 bar at 260°C) and it is built from carbon steel with a 3/16" minimum explosion bonded clad SA240-316L stainless steel interior. The overall dimensions of the autoclave are 32'10" long and 7'6" inside diameter with a 1.75" wall thickness (base metal). The autoclave is built to ASME Sec. VIII, Div. 1, 2007 Edition.

The autoclave was intended to be equipped with coils for minor heating or cooling duty. The solution is agitated during the reduction process with the four agitators.

3D Model View

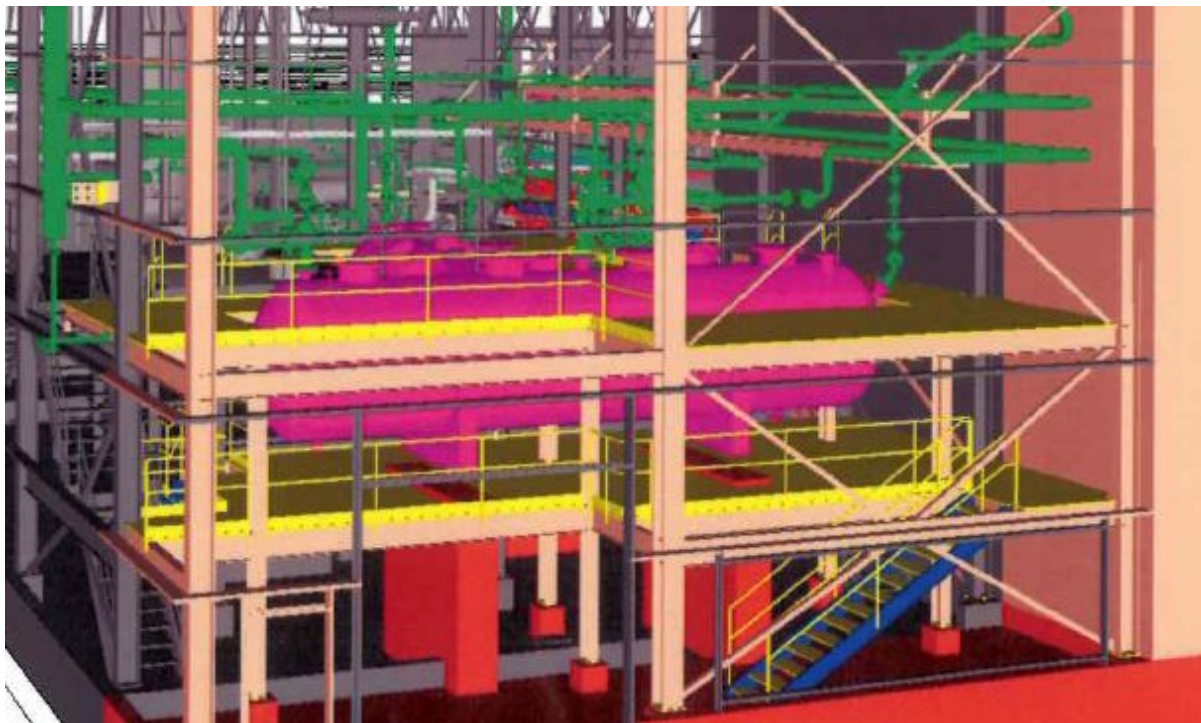

CONFIDENTIAL

Autoclave General Arrangement Drawing

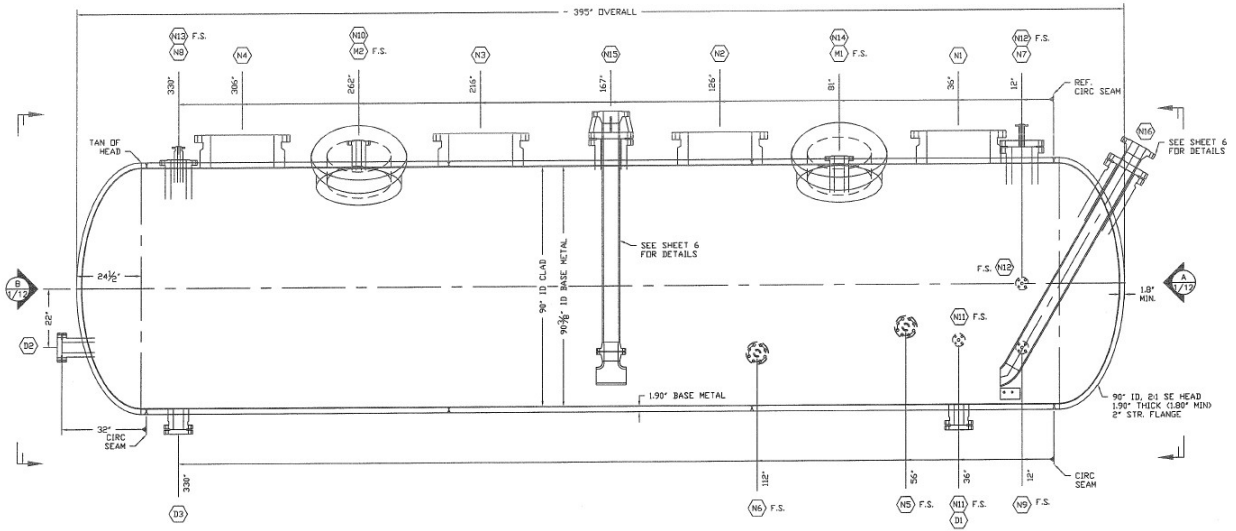

Heating Coil Detail

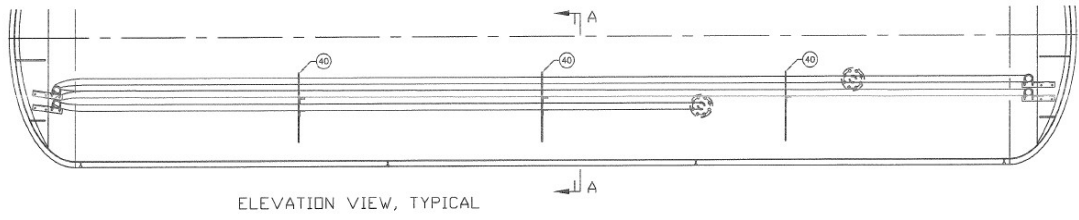

CONFIDENTIAL

Parts List:

Autoclave partially fabricated as follows:

- Vessel shell and heads welded as complete vessel
- Nozzles included but not installed

Components not included in the package:

- All agitator assemblies, including motors and gearboxes
- Mechanical seals (4)
- Instrumentation
- Piping
- Electrical cabling
- Valves & Fittings
- Platforms and Stairs
- Heating Coil
- Support Saddles

CONFIDENTIAL

Photos of Equipment

Autoclave Nozzles, Flanges (24")



Autoclave Vessel (in Back)

